

Рис. 1459, 62

(1:1)

注意：
 本图按比例放大，不得割裂并配齐全部零件。
 修理时应先参阅本图所列各零件名称，再按图号逐件
 修理。本图所列各零件之名称，均按国家标准命名。
 在本图上加注说明。

工 程 名 称 ENGINEERING
KM0407260
 图 名 NAME



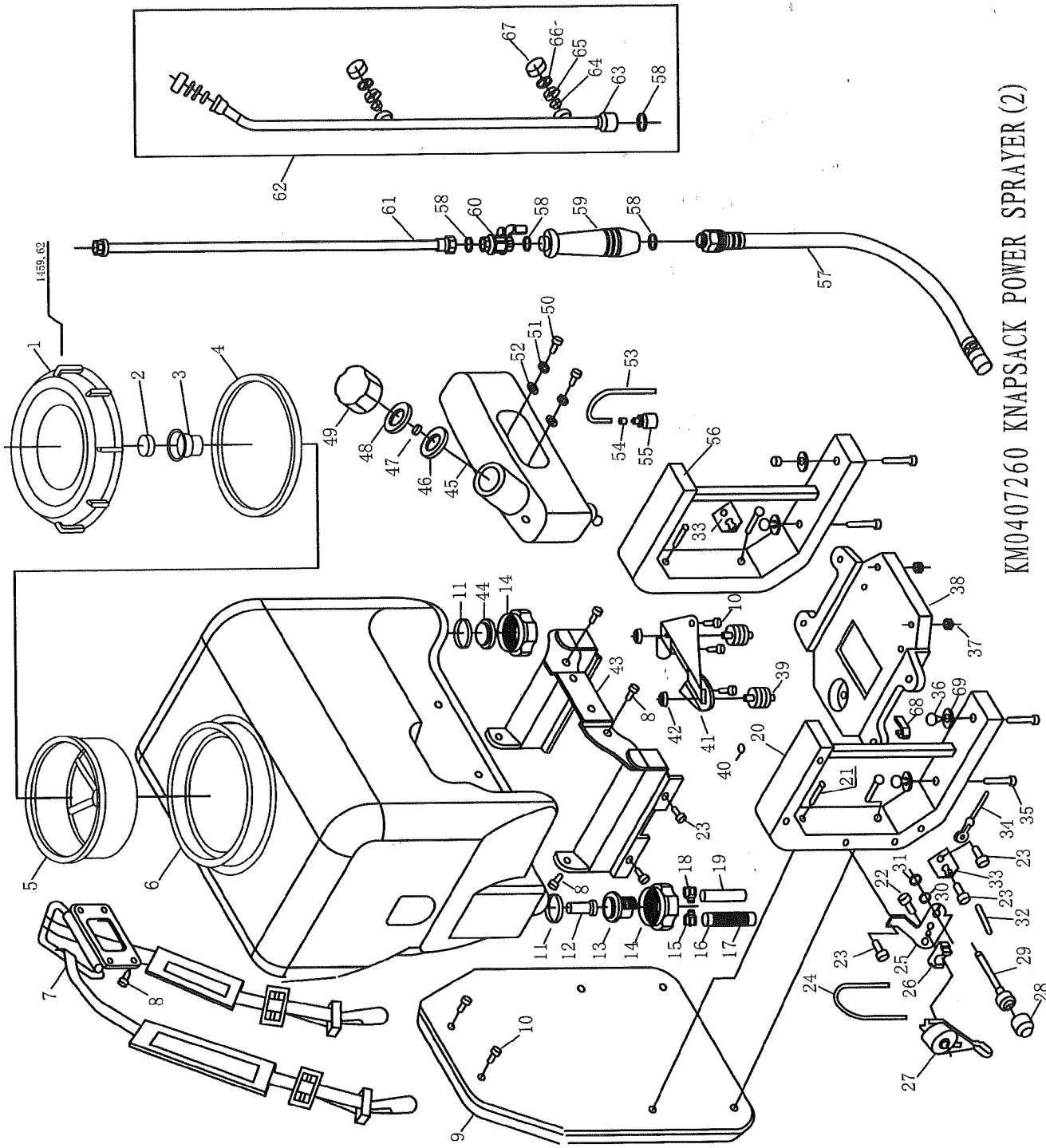

图 别	TITLE
比 例	SCALE
设 计	DESIGNER
制 图	DRAWER
校 对	COMPARER
审 核	CHECKING
步 骤	PROVEDBY
E	DATE
共 张	ADD. NO.
第 张	NO.
工 程 号	JOB NO.
图 纸 号	DWG NO.

(盖章有效)
 CAPTION OF DRAWING



KM0407260 KNAPSACK POWER SPRAYER (2)

SPRAYER TANK PART LIST

NO.	REF PHOTO	DESCRIPTION	QTY
1	 KM0407260T-1	LID	1
2		LID	1
3		LID	1
4	KM0407260T-4	SEALING WASHER	1
5	KM0407260T-5	FILTER ASSM	1
6	KM0407260T-6	CHEMICAL TANK ASSM	1
7	KM0407260T-7	BANDS ASSM	2
8		SCREW ASSM M6 X 12	1
9	KM0407260T-9	BACK MAT	1
10		SCREW ASSM M5 X 12	5
11	 KM0407260T-11	WASHER	2
12	KM0407260T-12	FILTER ASSM	1
13	KM0407260T-13	JOINT	1
14	 KM0407260T-14	LID NUT	2
15	KM0407260T-15	RING	1
16		HOSE Ø10 X 1.5 X 180	1
17	KM0407260T-17	FILTER ASSM	1
18	-18	RING	1
19		HOSE Ø8 X 1.5 X 75	1
20		LEFT FRAME	1
21		SCREW ASSM M5 X 30	1
22		SCREW ASSM M5 X 10	1
23		BOLT AM6 X 12	10
24	KM0407260T-24	THROTTLE	1
25		SWITCH SUPPORT	1
26		SWITCH SEAT	1
27	 KM0407260T-27	SWITCH	1



3WZ-6.5.2-1

3WZ-4.7.1-1

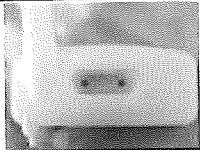

3WZ-4.7.4.1

3WZ-4.7.4-1

3WZ-4.7.4-2

28	KM 0407260T-28	SWITCH COVER	1
29	KM 0407260T-29	STOP SWITCH	1
30		WASHER 8	1
31		NUT M8	1
32		RING	2
33		FIXING PLATE	2
34		GROUND CONTACT	1
35		SCREW ASSM M6 X 35	4
36		NUT M6	4
37		NUT M6	3
38		PLATE	1
39	KM 0407260T-39	RUBBER MOUNT	3
40		O-WASHER 5 X 1.8	1
41		SUPPORT PLATE	1
42		NUT M6	1
43		FRAME	1
44		FRAME	2
45		TANK	1
46		FRAME	1
47		INLET	1
48		INLET SUPPORT	1
49	 KM 0407260T-49	LID (CUP)	1
50		BOLT ASSM M6 X 20	2
51		FUEL TANK PACK	2
52		RUBBER MOUNT	2
53		OIL TUBE Ø3 X 1.5 X 500	1
54		RUBBER PLUG	1
55	KM 0407260T-55	FILTER	1
56		RIGHT FRAME	1
57	KM 0407260T-57	RUBBER FRAME	1

~~1E34F.9.2-3A~~

58		WASHER	4
59		HANDLE	1
60	KM0407260T-60	VALVE	1
61	KM0407260T-61	SPRAYING ROD	1
62	KM0407260T-62	NOZZLE	1
63		SPRAY ROD	1
64	 KM0407260T-64	FILTER BOWL	3
65	 KM0407260T-65	SEALING RING	3
66	 KM0407260T-66	SPRAYING PLATE	3
67	KM0407260T-67	SPRAYING LID	3
68		WIRE BAND	1
69		WASHER 6	4

KNK

备注:
本图仅供参考, 不得照图制造。
如有疑问, 请向设计单位或
原设计单位联系。
设计单位: 中国机械工业
设计研究院

工 程 名 称
ENGINEERING

KM0407260

图 名
NAME

图 别	TITLE
比 例	SCALE
设 计	DESIGNER
制 图	DRAWER
校 对	CHECKER
审 核	APPROVED BY
日 期	DATE
共 张	TOTAL NO.
第 张	NO.
工 程 号	PROJECT NO.
图 纸 编 号	DWG. NO.

(盖章有效)
CAPTION OF DRAWING

Revision 1/260

1134F

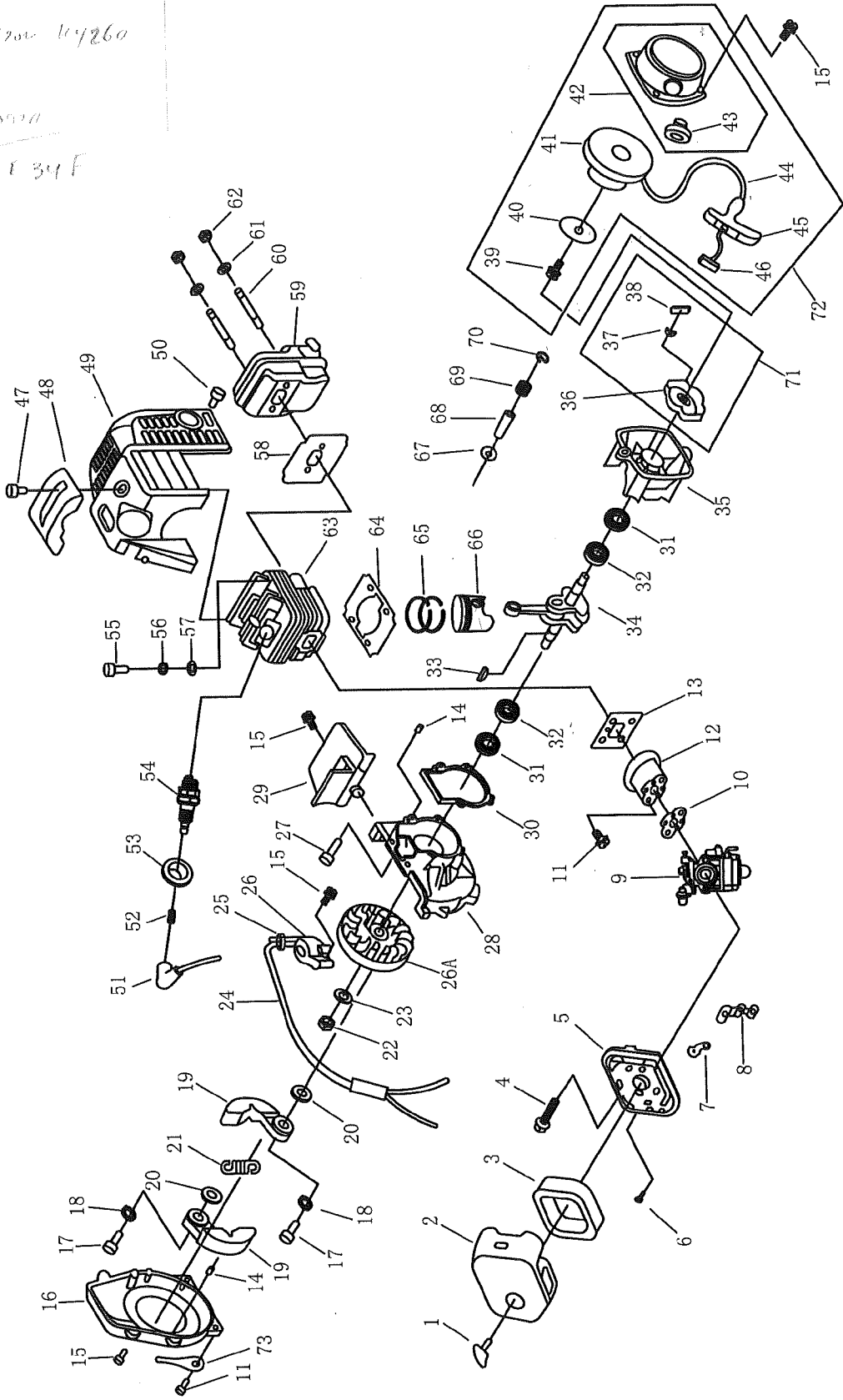





KM0407260 KNAPSACK POWER SPRAYER(3) 1E34F GASOLINE ENGINE

ENGINE PART LIST

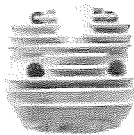
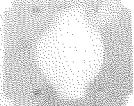
NO.	PART NO.	REF.PHOTO	DESCRIPTION	QTY
1	1E34F.1.2		SCREW	1
2	1E34F.1.4		AIR FILTER OUT COVER	1
3	1E34F.1-1		AIR FILTER SPONGE	1
4	GB9074.4		SCREWM5 X 55	2
5	1E34F.1.1		AIR FILTER INSIDE COVER	1
6	GB845		SCREWST4.2X12-F-H	1
7	1E34F.1-3		CHOKE	1
8	1E34F.1-2		CHOKE HANDLE	1
9	1E34F.13		CARBURETOR	1
10	1E34F-1		GASKET	1
11	GB9074.4		SCREWM5 X 20	6
12	1E34F.4		INLET MAINFOLD	1
13	1E34F-2		CYLINDER WASHER	1
14	GB119		ANNUL B3 X 10	4
15	GB9074.4		SCREWM4 X 16	9
16	1E34F-5		FAN COVER	1
17	1E34F-12		CLUTCH STEP SCREW	2
18	1E34F-13		WASHER	2
19	1E34F.10.1		CLUTCH SHOE COMP.	2
20	1E34F-11		WASHER	2
21	1E34F.10-1		CLUTCH SPRING	1
22	GB6171		NUT M8 X 1	1
23	GB97.1		WASHER 8	1
24	1E34F.5.1		STOP CORD COMP.	1

25	1E34F.5-1		PRIMARY CORD GROMMET	1
26	GB9074.4		MAGNETO STATOR	1
26A	1E34F.5-2		MAGNETO ROTOR	1
27	GB9074.4		SCREW M5 X 25	4
28	1E34F.7-1		FRONT HALF CRANK CASE	1
29	1E34F-4		GUIDE PLATE	1
30	1E34F.7-2		CRANK CASE GASKET	1
31	1E36F.2		OIL SEAL	2
32	GB276		BALL BEARING 6001/P5	2
33	1E40FP-3Z.3-1		KEY	1
34	1E34F.6.1		CRANK SHAFT COMP.	1
35	1E34F.7-3		REAR HALF CRANK CASE	1
36	1E34F.8.1		STARTER PULLEY ASSY	1
37	1E34F.8-2		STARTER PAWL SPRING	1
38	1E34F.8-1		STARTER PAWL	1
39	GB9074.6		SCREW M5 X 10	1
40	1E34F.11-1		RECOIL SPRING	1
41	1E34F.11-2		STARTER ROPE REEL	1
42	1E34F.11G.1		RECOIL STARTER BODY	1
43	1E34F.11.1-1		ROPE GUIDE	1
44	1E34F.11-3		ROPE	1
45	1E36F.1-1		STARTER HANDLE	1
46	1E36F.1-5		GASKET	1
47	GB9074.4		SCREW M5 X 14	1
48	1E34F-6		COVER	1
49	1E34F.3		COVER	1
50	GB9074.4		SCREW M4 X 12	1
51	1E34F.5-2		PLUG CAP	1
52	1E40F-3A.8-2		CLICK SPRING	1
53	1E34F.5-3		PLUG COVER	1
54	RCJ6Y(CHAMPION)		SPARK PLUG	1
55	GB70		SCREW M5 X 20	4
56	GB93		WASHER 5	4

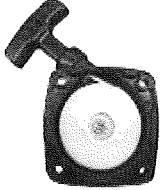
57	GB848		WASHER 5	4
58	1E34F-3		GASKET	1
59	1E34F.2		MUFFLER COMP.	1
60	1E34F-14		BOLT	2
61	GB96		WASHER 5	2
62	GB6187		NUT M5	2
63	1E34F-8		CYLINDER	1
64	1E34F-9		CYLINDER WASHER	1
65	1E34F.6-5		PISTON RING	2
66	1E34F.6-6		PISTON	1
67	1E34F.6-1		STOP RING	2
68	1E34F.6-3		PISTON PIN	1
69	1E34F.6-4		NEEDLE BEARING	1
70	1E34F.6-2		PISTON PIN CIRCLE	2
71	1E34F.8		STARTER PULLEY	1
72	1E34F.11G		STARTER	1
73	1E36FF-11		FLASH PAN	1

KNK

备注:
 本图系由国外引进, 仅供参考, 不得照抄。
 如需在本图基础上进行修改, 须经设计人同意。
 现图按图号标注之顺序, 如原图有更改, 须经设计人同意。
 五三工程局设计所

工 程 名 称
 ENGINEERING

KM0407260

图 名
 NAME

图 例	TITLE
比 例	SCALE
设 计	DESIGNER
校 核	DRAWER
审 核	COMPAREN
审 定	CHECKING
审 定	PROCEED
共 张	DATE
第 张	ADD. NO.
工 程 编 号	JOB NO.
图 纸 编 号	DWG. NO.

(盖章有效)
 CAPTION OF DRAWING





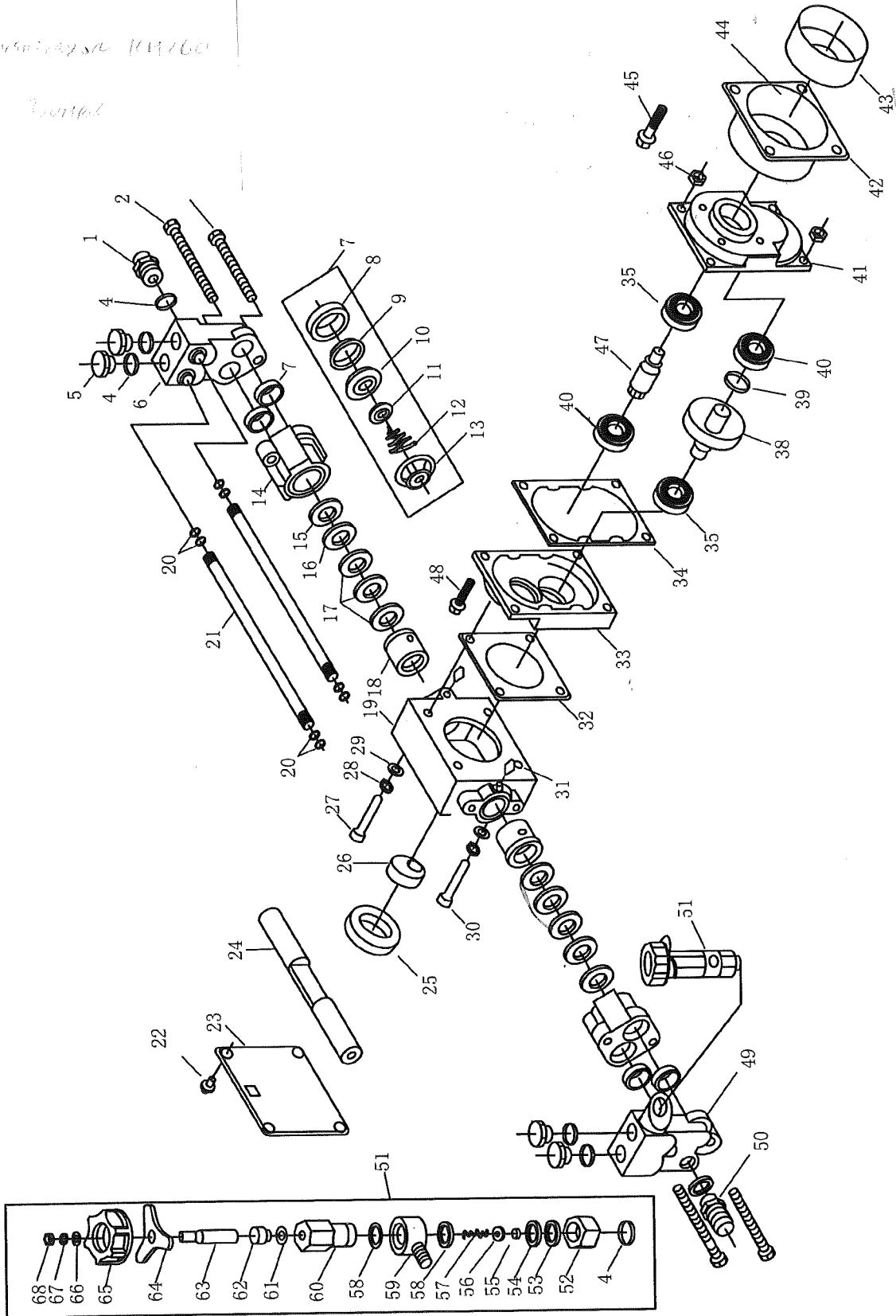





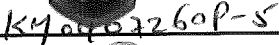

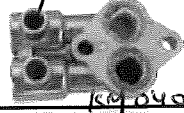

KM0407260

Normal



KM0407260 KNAPSACK POWER SPRAYER (1)

SPRAYER PUMP PART LIST

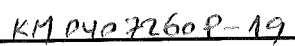
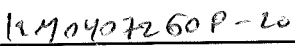
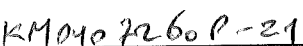
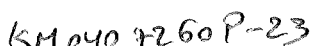
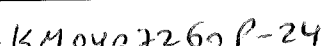
NO.	REF PHOTO	DESCRIPTION	QTY
1		OUTLET JOINT	1
2		BOLT ASSM M6 X 70	2
3		BOLT ASSM M6 X 60	2
4		O-WASHER 9 X 1.8	6
5	 	CLOGGING BOLT	4
6	 	CHAMBER	1
7	 	INLET AND OUTLET VALVE	4
8		SEALING RING	4
9		VALVE SUPPORT	4
10		VALVE SEAT	4
11		VALVE DISK	4
12		VALVE SPRING	4
13		VALVE COVER	4
14	 	CHAMBER	2
15	 	WASHER	2
16	 	SUPPORTING RING	2
17	 	V-RING	6
18	 	TUBE	2
19		CRANKCASE	1
20		O-WASHER 5 X 1.8	8
21		TUBE	2
22		SCREW ASSY M5 X 12	4
23		LID	1
24		PISTON	1

25	KM0407260P-25	BEARING 61905	1
26	KM0407260P-26	WHEEL	1
27		SCREW M5 X 20	2
28		WASHER 5	4
29		WASHER 5	4
30		SCREW M5 X 35	2
31		BOTTLE	2
32	KM0407260P-32	SEALING WASHER	1
33	KM0407260P-33	BOX	1
34	KM0407260P-34	BOX WASHER	1
35	KM0407260P-35	VALVE COVER	2
38	KM0407260P-38	SPINDLE	1
39	KM0407260P-39	WASHER	1
40	KM0407260P-40	BEARING 6001-2RS/P6	2
41	KM0407260P-41	BOX LID	1
42	KM0407260P-42	CLUTCH DRUM COVER	1
43		CLUTCH DRUM ASSY	1
44		SCREW ASSY M5 X 12	4
45		BOLT ASSY M6 X16	4
46		NUT M5	4
47	KM0407260P-47	GEAR SHAFT	1
48		BOLT ASSY M5 X 20	2
49	KM0407260P-49	ABSORBING CHAMBER	1
50	KM0407260P-50	INLET JOINT	1
51	 KM0407260P-51	VALVE	1
52		BOTTOM SUPPORT	1
53		SEALING WASHER	1
54		VALVE SEAT	1
55		STEEL BALL	1
56		SPRING SUPPORT	1
57		SPRING	1
58		O-WASHER 14 X 1.8	2

59		TUBE COMP	1
60		INNER TUBE	1
61		O-WASHER 6.9 X 1.8	1
62		SPRING SUPPORT	1
63		LOCK NUT	1
64		LOCK HOLDER	1
65	KM0407260P-65	RECULATING SCREW	1
66		WASHER 5	1
67		WASHER 5	1
68		NUT M5	1